

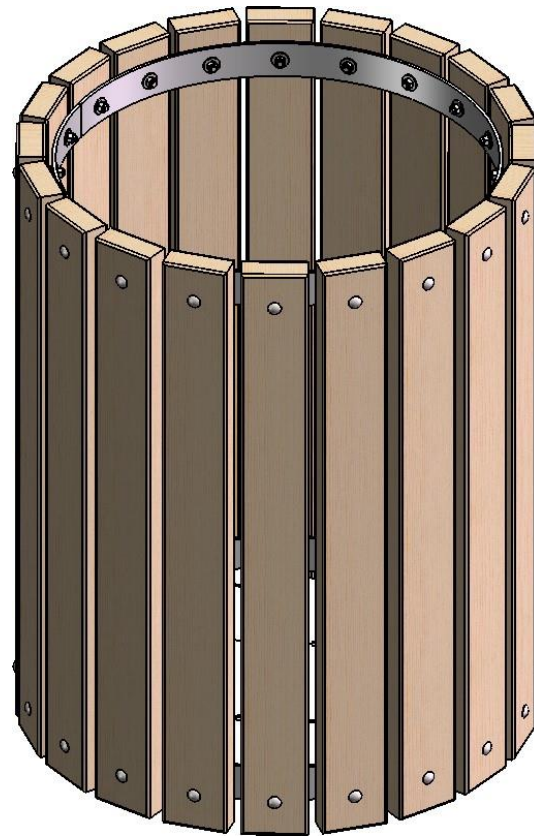

A PLAYCORE Company



Model # TR-32



WARRANTY & TERMS

WARRANTY: 5 Year Limited Warranty on Thermoplastic coated elements. Ultra Play guarantees all items for one full year to be free of defects in workmanship or materials when installed and maintained properly. We agree to repair or replace, any items determined to be defective. Items specifically not covered by this warranty include vandalism, man made or natural disasters, lack of maintenance, normal weathering or wear and tear due to public abuse.

Damages or loss in transit is the responsibility of the carrier, whether visible or concealed. It is the responsibility of the recipient to assure that the order is received complete. Before signing the delivery receipt, inspect the shipment immediately and completely. Note any damages or shortages on the bill of lading. Damage reports must be filed within 10 days. Ultra Play is NOT responsible for damages or loss in transit. Title to all goods passes to the customer at the time of shipment. Ultra Play will assist in filing claims if the freight arrangements were made by Ultra Play at your request.

CANCELLATIONS AND RETURNS: Cancellations are only accepted with approval of Ultra Play. No merchandise shall be returned without a Return Goods Authorization number which is issued by customer service. Any authorized merchandise must be carefully packed and received in saleable condition. A restocking charge of up to 25% will be applied to all returned goods when the error is not the fault of Ultra Play. All returns must be shipped freight prepaid.



A PLAYCORE Company

SAFETY WARNINGS & EQUIPMENT INSPECTION

- Owners and installers please note these safety warnings and make use of this checklist on a regular basis.
- Follow installation instructions when erecting equipment.
- Ground surfaces around equipment should be restored as needed. Concrete footings should never be exposed. Surface depth should comply with ASTM and CPSC specifications.
- Check for and repair damage caused by wear or vandalism, a major factor in injury causing situations.
- All protruding bolts should be covered or cut off and finished smooth. Sharp edges on pipes should be capped or removed. Check for bent, broken, or severely worn pipe, and replace.
- All equipment should be free of rust and repainted whenever necessary to deter rusting.
- We provide our customers with layout sheets and installation instructions. Please keep on file the specifications sheet that contains the listing of every part used.
- Never add components not intended for use with this product.
- Regular maintenance is necessary in this and all park and recreational equipment to insure the safety of the user.
- Note: Proper maintenance of equipment requires regular tightening of all bolts, nuts, and setscrews.
- Note: Regular checking of all parts, castings, etc. should be made. If a part is broken or worn, it should be replaced immediately.
- Check to be sure all fittings are tight and that bars and pipes do not move.
- Replace all worn S-hooks. S-hooks must be completely closed. Failure to close S-hooks can result in serious injury to the user. NEVER reuse S-hooks.
- Test for free movement of swing hanger and other moving attached parts.
- Check for worn chains and replace them.
- A soft resilient surface should be placed under all swings extending at least twice the height of the top rail both front and back.

HARDWARE AND TOOLS REQUIRED

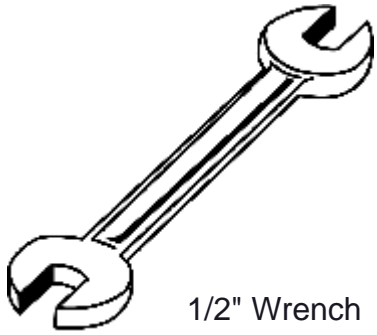

1/2" Wrench

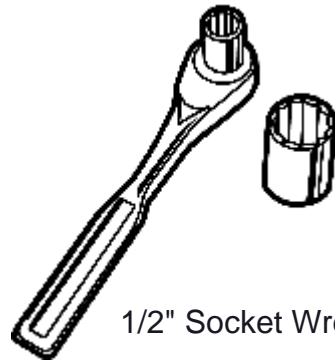

1/2" Socket Wrench

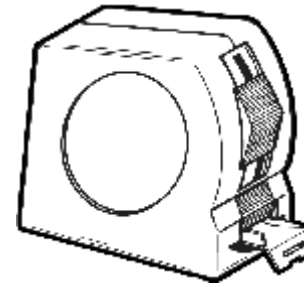

Tape Measure

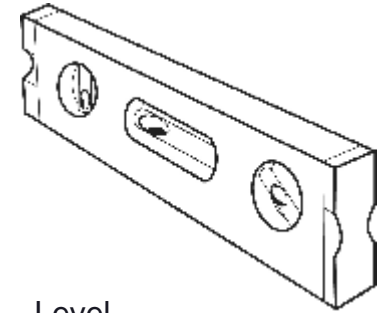

Level

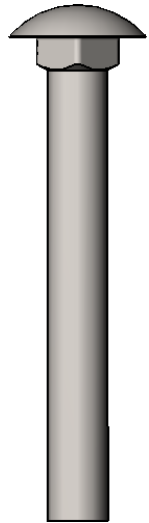

5/16" x 2-1/2"
Carriage Bolt

5/16" x 2"
Carriage Bolt

5/16" Washer

5/16" Hex Nut

3/8" Hex Nut

ULTRA SITE PRODUCT SPECIFICATIONS

TR-32 WOOD SLAT TRASH RECEPTACLE

Slats: Planking is made from 2" x 4" No. 1 KDAT Southern Yellow Pine ACQ pressure treated lumber is used exclusively by Ultra Play Systems (TR-32-PT), 2" x 4" No. 1 Southern Yellow Pine, finished in redwood stain with wood preservative (TR-32-T), or 2" x 4" No. 1 Southern Yellow Pine (TR-32-U).

Frame: Rings are 3/16" x 2" flat. Bottom plate is precision punched from 12 ga. steel sheet. All electrically MIG welded.

Frame Coating: Hot dipped galvanized.

Hardware: All hardware fasteners are zinc coated.

Dimensions: 26" Diameter. trash receptacle has an overall height of 34".



COMPONENTS

Attach the 34" Wood planks to the TR-32 Ring and TR Bottom Ring assembly as shown using specified hardware.

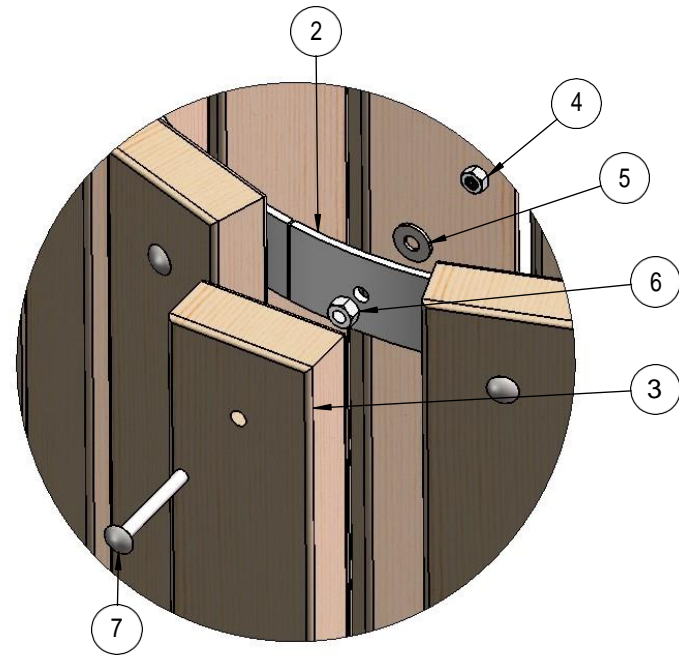
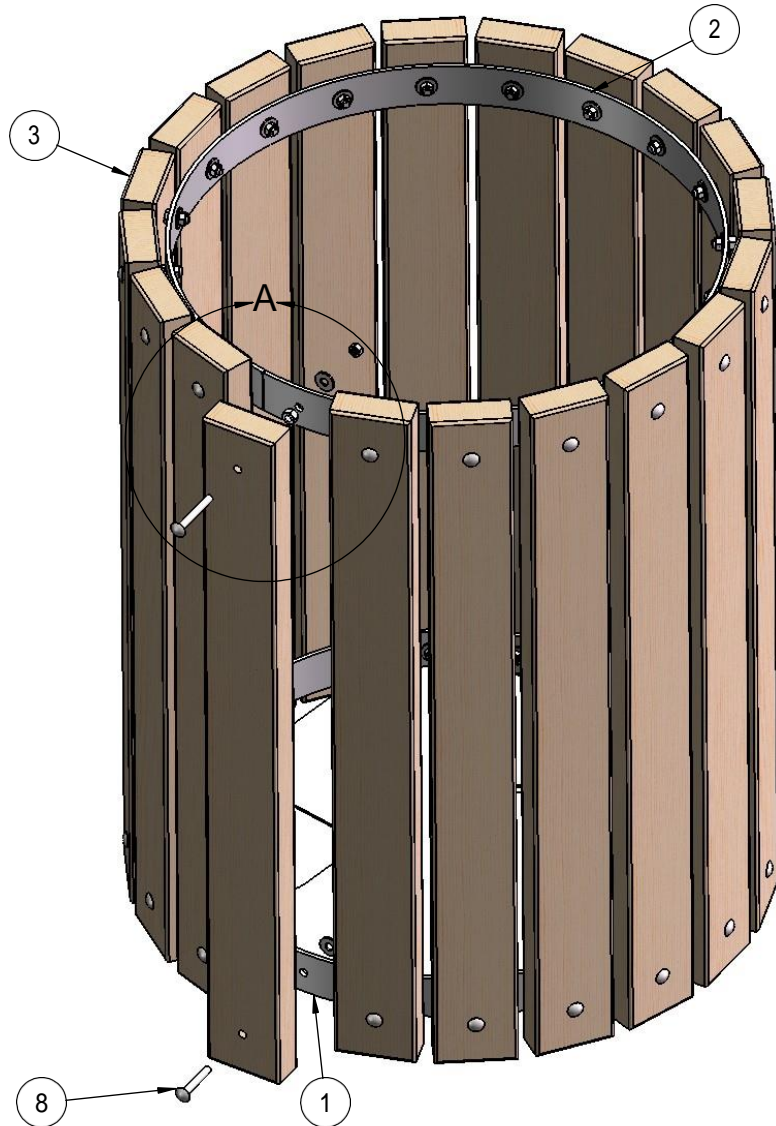

Note: 3/8" Hex Nuts fit on the 5/16" x 2-1/2" Carriage Bolts between the Recycled Planks and the TR-32 Ring on TOP only. **This must be done in order for top to fit.**

ITEM NO.	PartNo	DESCRIPTION	QTY
1	01-05-0054	TR bottom ring assembly	1
2	01-05-0049	TR-32 Ring	1
3	P134-2x4-1R, RST34-2x4-TR, or U34-2x4-TR	2 x 4 Pressure Treated 1R Plank (34"), 2 x 4 Redwood Stained TR Plank (34"), or 2 x 4 Untreated TR Plank (34")	20
4	33-U1-0001	5/16" Hex Nut (Zinc)	40
5	33-02-0001	5/16" Zinc Plated Washer	40
6	33-01-0002	3/8" Hex Nut (Zinc)	20
7	33-06-0019	5/16" x 2-1/2" Carriage Bolt (Zinc)	20
8	33-06-0002	5/16" x 2" Carriage Bolt (Zinc)	20

OVERALL DIMENSIONS

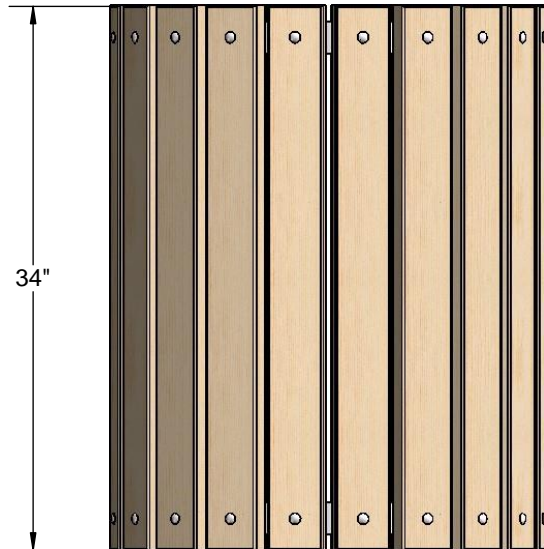
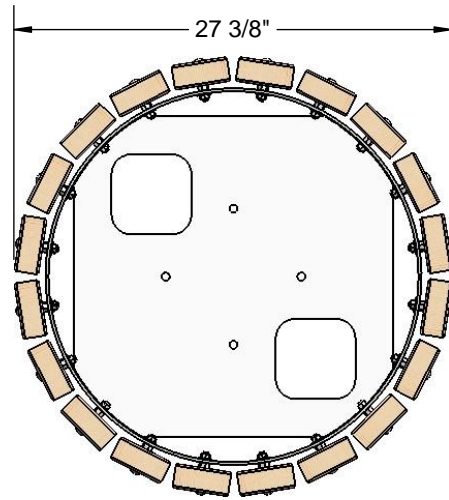

INGROUND MOUNTING OPTION

INGROUND MOUNT FOR TRASH RECEPTACLE

Frame: 2-3/8" O.D. x 12 gauge pre-galvanized structural steel tubing. Mounting points 3 gauge 8" x 8" steel flat bar. All electrically MIG welded.

Frame Coating: Electrostatic powder coated application oven cured.

Hardware: All stainless steel hardware fasteners. (Included).

Dimensions: Overall dimension is 24 1/4" x 8" x 8".

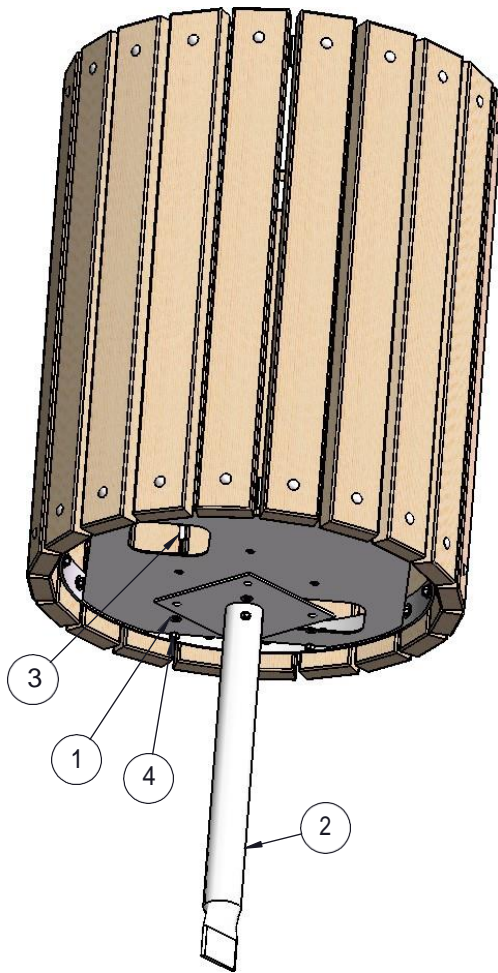

Attach the IG KIT to the TR-32 as shown using specified hardware.

Estimated Required Concrete:
5 - 50lb Bags of Concrete Mix

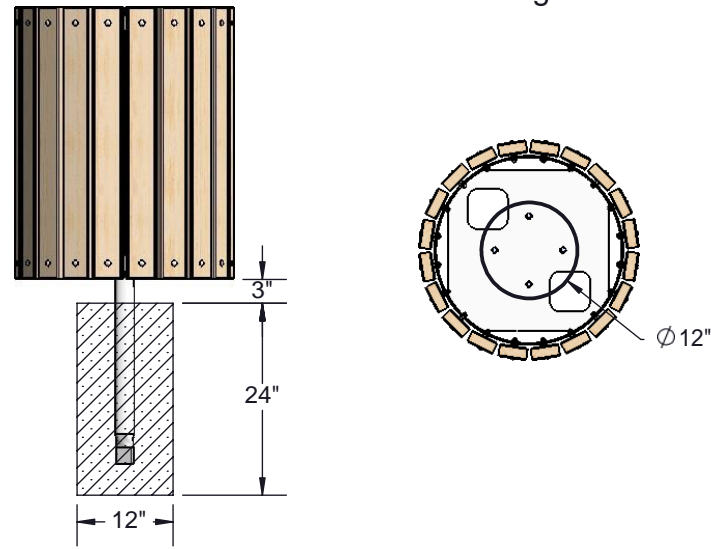

ITEM NO.	PartNo	DESCRIPTION	QTY
1	33-02-0007	5/16" SS Washer	8
2	P-01-05-0052	receptacle inground mount	1
3	33-05-0029	5/16" x 1" Machine Bolt (SS)	4
4	33-03-0012	5/16" Keps Nut (SS)	4

SURFACE MOUNT MOUNTING OPTION

SURFACE MOUNT FOR TRASH RECEPTACLE

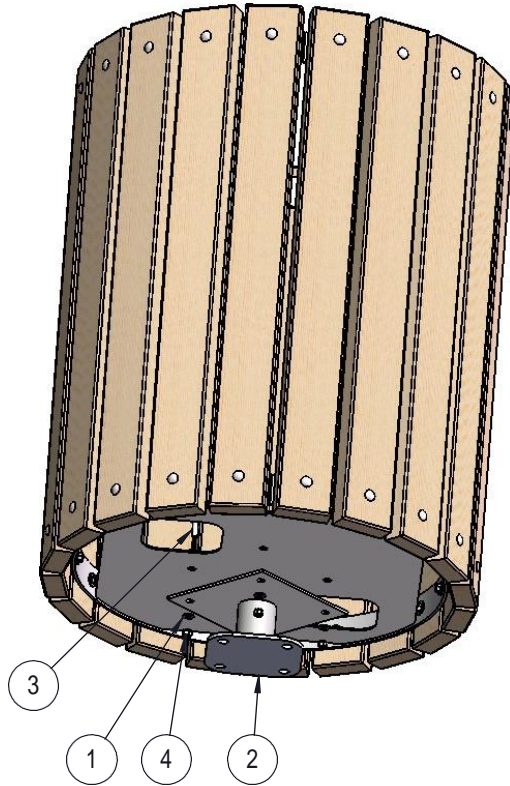

Frame: 2-3/8" O.D. x 12 gauge pre-galvanized structural steel tubing. Surface mounting points are 3 gauge 8" x 8" steel flat bar with four holes. Receptacle mounting points are 3 gauge 6" x 6" steel flat bar with 4 holes. All electrically MIG welded.

Frame Coating: Electrostatic powder coated application oven cured.

Hardware: All stainless steel hardware fasteners. (Included).

Dimensions: Overall dimension is 3-3/4" x 8" x 8".

Attach the SM KIT to the TR-32 as shown using specified hardware.

Recommended Surface Mount Hardware:
3/8" x 3-1/2" Concrete Expansion Anchor Bolts
(Not Included)

ITEM NO.	PartNo	DESCRIPTION	QTY
1	33-02-0007	5/16" SS Washer	8
2	P-01-05-0053	receptacle surface mount	1
3	33-05-0029	5/16" x 1" Machine Bolt (SS)	4
4	33-03-0012	5/16" Kep Nut (SS)	4

LINER OPTION

PL-32
32 Gallon Liner

Made of heavy duty plastic.



TOP OPTIONS

32 GALLON FLAT TOP

Material: Top plate shall be fabricated from 18 gauge steel flat, spun to form. Outside shall have a 1" radius.

Coating: Oven fused functionalized polyethylene copolymer-based thermoplastic.

Fluidized bed coating application with superior mechanical performance, impact resistance and UV-stability.

32 GALLON RAIN BONNET TOP

Material: Top plate shall be fabricated from 18 gauge steel flat, spun to form. Vertical posts are 1/2" diameter steel rods. Bonnet top shall be fabricated from 20 gauge steel flat, spun to form. All electrically MIG welded.

Coating: Oven fused functionalized polyethylene copolymer-based thermoplastic.

Fluidized bed coating application with superior mechanical performance, impact resistance and UV-stability.

FTR-32-08

Receptacle Top Dimensions:
Center opening shall be an 8" inside diameter. The overall dimensions shall be 24" diameter x 2" high.

FTR-32-14

Receptacle Top Dimensions:
Center opening shall be an 14" inside diameter. The overall dimensions shall be 24" diameter x 2" high.

RBR-32-08

Receptacle Top Dimensions:
Center opening shall be an 8" inside diameter. The overall dimensions shall be 24" diameter x 11" high.

RBR-32-14

Receptacle Top Dimensions:
Center opening shall be an 14" inside diameter. The overall dimensions shall be 24" diameter x 11" high.

Note: 3/8" Hex Nuts must be on the 5/16" x 2-1/2" Carriage Bolts between the Recycled Planks and the TR-32 ring on TOP only in order for top to fit.



TOP OPTIONS

32 GALLON ASH URN TOP

Material: Top plate shall be fabricated from 18 gauge steel flat, spun to form. Vertical posts are 1/2" diameter steel rods. Bonnet top shall be fabricated from 20 gauge steel flat, spun to form. Ash urn shall be fabricated from 20 gauge steel flat, spun to form. All electrically MIG welded.

Coating: Oven fused functionalized polyethylene copolymer-based thermoplastic.

Fluidized bed coating application with superior mechanical performance, impact resistance and UV-stability.

AUR-32-08

Receptacle Dimensions:
Center opening shall be an 8" inside diameter. The overall dimensions shall be 24" diameter x 11-1/4" high.

AUR-32-14

Receptacle Dimensions:
Center opening shall be an 14" inside diameter. The overall dimensions shall be 24" diameter x 11-1/4" high.

Note: 3/8" Hex Nuts must be on the 5/16" x 2-1/2" Carriage Bolts between the Recycled Planks and the TR-32 ring on TOP only in order for top to fit.

